



TIGZONE SERIES

AIR COOLED

TIG-Torches

The TIGZONE Air-cooled series is the high-quality standard in TIG welding. With their wide range of accessories, the air-cooled TIG torches already cover the majority of all TIG applications - power range from 50 to 200 amps.

- One-piece and two-piece torch-cable configurations available
- Torch heads made from the highest quality copper alloys
- Available for all standard welding machines
- 3 different handle and switch options
- Super-Flex cables and Super-Soft leather remains flexible and ease to handle with a significant cable lifetime
- Excellent for portable applications - no water-cooler require
- CE EN 60 974-7



Torch (model)	A DC (EN 60974-7)	A AC (EN 60974-7)	WØ (in mm)	Page
AE-9	125	100	0.5 – 3.2	5
AE-17	150	115	0.5 – 4.0	11
AE-26	200	150	0.5 – 4.0	18
AE-24	80	50	1.0 – 3.2	25

HANDLE SERIES TIGZONE HD

Are you working on the construction site or in an environment where rough conditions prevail? Then the TIGZONE HD with its robust design, high frequency characteristics and metal switch blades for more finger control is the right choice. The handle is equipped with a microswitch with gold contacts and is completely insulated thanks to the switch sleeve. The switch module is available as a flat, curved single module or as a red/green double print, depending on your needs. The TIGZONE HD is available in three sizes: Small, Medium, and Large.







Trigger / Switches Parts			Trigger / Switches Complete	
SW-1-3 	SW-1-1 	SW-1-2 	SW-1 	SW-4
SW-1-4 			SW-1F 	SL-3 Switch Lever for SW-1F

	Compatible Torches	Adapter	Handle	Switch Boot
TIG	AE9, AE9SN, AE17, AE17SN, AE150		H-100 	BS-1
	CK9, CK17, CK24, CKPF130, MR70, FL130, FL150		CK-HS 	
TIG	AQ20, AE24, AQ24, AQ225, AQ225SN, AQ250SN	HI-100G 	H-100G 	BM-1
	CK20, CK25, CK24W, MR140, FL230, FL250		CK-H23 	
	CK230, TL26, TL18			
TIG	AQ18, AQ18SC, AE26, AE200, AE300		H-200 	BL-1
	CK18, CK26, CK510		CK-HL 	

HANDLE SERIES TIGZONE Ergo

The TIGZONE Ergo not only impresses with its high frequency properties but is also suitable for both right-handed and left-handed users thanks to its ergonomic design. The switch module is available as a single-pressure or double-pressure version. The handle is particularly easy to repair, as no screws or tools are required, and is available in size Small and Large.



Trigger / Switches Parts	
TZ-RB-1 	TZ-BB-3 
TZ-RB-2 	TZ-BB-4 

Compatible Torches		Handle
TIG  AE9, AE9SN, AE17, AE17SN, AE150, AQ20, AE24, AQ24, AQ225, AQ225SN, AQ250SN		TZ-S-T
 CK230, TL26, TL18, CK9, CK17, CK24, CKPF130, MR70, FL130, FL150, CK20, CK25, CK24W, MR140, FL230, FL250		
TIG  AQ18, AQ18SC, AE26, AE200, AE300		TZ-L-T
 CK18, CK26, CK510		

HANDLE SERIES

TIGZONE Butterfly

The TIGZONE Butterfly handle has a lightweight design and a ball-and-socket joint that adapts ergonomically to any hand. The special feature of the Butterfly is that it has an up/down function with four buttons. This allows users to send a digital signal to the machine to adjust the power up and down. The switch module of the TIGZONE Butterfly is also available as a single or double switch version.



Trigger / Switches Parts			Handle sets Complete with Trigger	
TZ-BC-1 	TZ-BC-2 	TZ-BB-8 	TZ-BF-1 ↓ 	
		TZ-BB-9 	TZ-BF-2 ↓ ↓ 	
TZ-BC-3 	TZ-BB-5 	TZ-BFUP-T ↑ ↓ ↓ ↑ 		

Compatible Torches	Handle	Cable Support
AE9, 9SN, AE17, AE17SN, AE150, AQ20, AE24, AQ24, AQ225, AQ225SN, AQ250SN	TZ-BF-L/R 	TZ-BF-CS

TIG



CK9, CK17, CK24, CKPF130, MR70, MR140, CK20, CK25, CK24W, CK230, TL26, TL18, FL130, FL150, FL230, FL250

TZ-PS-1

1 x

i **Screws**

You need 4 (four) screws to assemble one handle.

AIR COOLED SERIES

AE-9**TIGZONE®**
TORCHES**TIGZONE AE-9 – aircooled TIG-Torch****The Torch**

Small and lightweight profile torch series designed for optimal control, especially in hard-to-reach places. Variety of torch body configurations suited to diverse welding applications

The Cable

Super-Flex® cables and Super-Soft® leather remains flexible and ease to handle with a significant cable lifetime

The End-Connector

Available for all standard welding machines

The Handle

3 Different handle and switch options

DIN Norm

CE EN 60 974-7

TIGZONE AE-9 – Torch / Back End Consumables



Torch Front Group

1	Torch Body incl. insulator (10)	
.1	AE-9	AE9
.2	AE-9V	AE9V
.3	AE-9F115	115 mm AE9F115
.4	AE-9F	90 mm AE9F
.5	AE-9FV	90 mm AE9FV
.a	9F	90 mm 9F
.b	AE-150TB	AE150TB
.c	AE-150VTB	AE150VTB
.d	VS-2	VS2

2	Backcap	
.1	short	41V33
.2	medium	41V35
.3	long	41V24

Cable Group

4	Cable cover leather	TZ-1022R-TIG
5	Cable cover 22x1.5mm	RS-22
6	Power Cable	
	4m	57Y01R-*
	4m SF	57Y01R-SF-*
	8m	57Y03R-*
	8m SF	57Y03R-SF-*
7	Control	MOQ 100m
	Standard (3x0.5mm)	LIYY-3x0,5
	U/D Torches (6x0.25mm)	LIYCY-6x0,25

* Please specify machine connections e.g. 1/4, 3/8 etc.

i H-100 Handle

Fits AE9/9F/9FV/9F115 bodies.
Ordering Number: **H-100**



i Handles

More information regarding our **Handles** Group on page 2.

TIGZONE AE-9 – Front End Consumables Overview

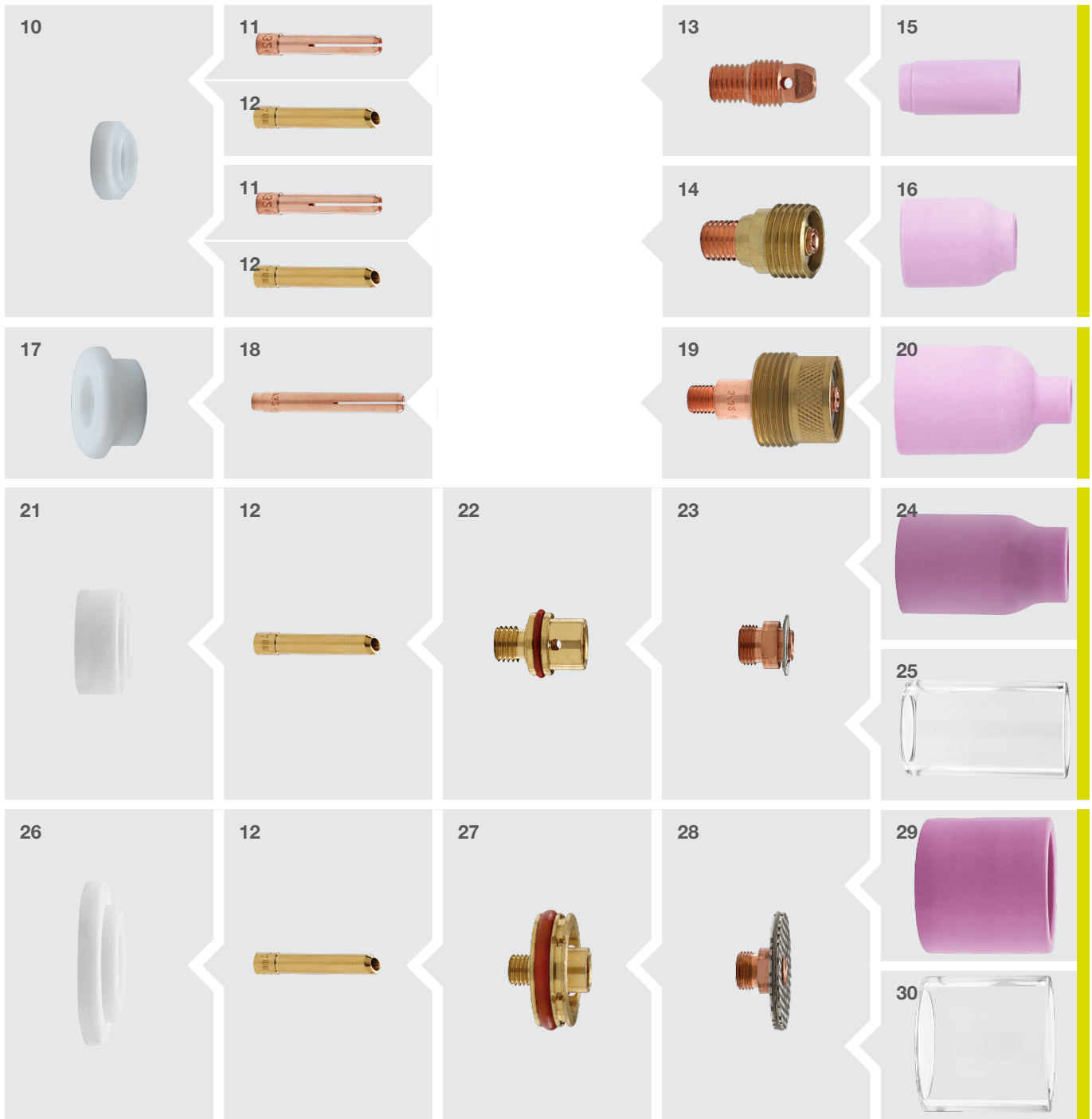

TIGZONE AE-9 – Front End Consumables

i Parts

These parts come in different **materials, variants** and **sizes**.

For additional information see below.

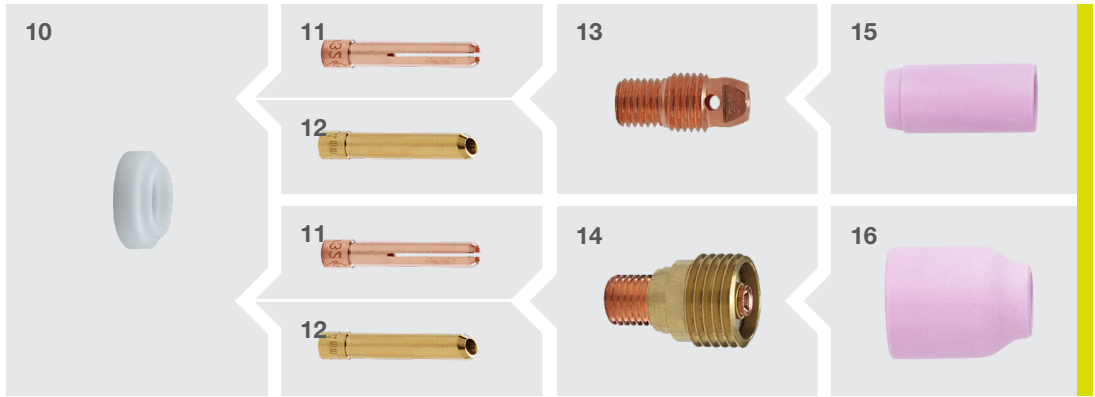

i Cup Sizes

Have a look at the different sizes of the same cup.



Size	10 Insulator (std.)	11 Collet	12 Collet Wedge	13 Collet Body	14 Gas Lens
Ø .020" (0.5 mm)		13N20	-	13N25	45V41
Ø .040" (1.0 mm)		13N21	2C040GS	13N26	45V42
Ø 1/16" (1.6 mm)	598882	13N22	2C116GS	13N27	45V43
Ø 3/32" (2.4 mm)		13N23	2C332GS	13N28	45V44
Ø 1/8" (3.2 mm)		13N24	2C418GS	13N29	45V45

Size	15 Cup (29,35 mm)	15 Super Cup (Sil.Nitride)	15 Cup L (48 mm)	15 Cup XL (63 mm)	16 Cup (25,40 mm)	16 Super Cup (Sil.Nitride)	16 Cup L (35 mm)	16 Cup XL (72 mm)
#3 Ø 4.75 mm	-	-	A796F70	A796F74	-	-	-	-
#4 Ø 6.35 mm	13N08	13N08SC	A796F71	A796F75	53N58	53N58SC	53N58L	53N58XL
#5 Ø 7.93 mm	13N09	13N09SC	A796F72	A796F76	53N59	53N59SC	53N59L	53N59XL
#6 Ø 9.52 mm	13N10	13N10SC	A796F73	A796F77	53N60	53N60SC	53N60L	53N60XL
#7 Ø 11.11 mm	13N11	13N11SC	-	-	53N61	53N61SC	53N61L	53N61XL
#8 Ø 12.70 mm	13N12	13N12SC	-	-	53N61S	53N61SSC	53N61SL	-
#10 Ø 15.87 mm	13N13	13N13SC	-	-	53N61S-10	-	-	-

TIGZONE AE-9 – Front End Consumables

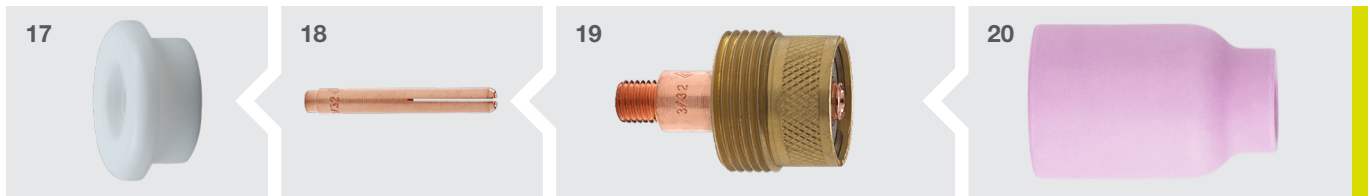

	17 Insulator for large Gaslens	18 Collet long	19 Gas Lens L
Size			
Ø .020" (0.5 mm)		13N20L	45V0204S
Ø .040" (1.0 mm)		13N21L	45V0204S
Ø 1/16" (1.6 mm)		13N22L	45V116S
Ø 3/32" (2.4 mm)		13N23L	45V64S
Ø 1/8" (3.2 mm)		13N24L	995795S
	54N63-20		

i Parts

These parts come in different **materials, variants** and **sizes**.

For additional information see below.

	20 Cup LD (47,62 mm)	20 Super Cup LD (Sil.Nitride)	20 Cup LD L (70 mm)	20 Cup LD XL (84 mm)	20 Cup LD XXL (122 mm)
Size					
#3 Ø 4.75 mm	-	-	-	-	-
#4 Ø 6.35 mm	-	-	-	-	-
#5 Ø 7.93 mm	-	-	-	-	-
#6 Ø 9.52 mm	57N75	57N75SC	57N75L	57N75XL	57N75XXL
#7 Ø 11.11 mm	-	-	-	-	-
#8 Ø 12.70 mm	57N74	57N74SC	57N74L	57N74XL	57N74XXL
#10 Ø 15.87 mm	53N88	53N88SC	53N88L	53N88XL	53N88XXL
#12 Ø 19.05 mm	53N87	53N87SC	53N87L	53N87XL	53N87XXL

TIGZONE AE-9 – Front End Consumables

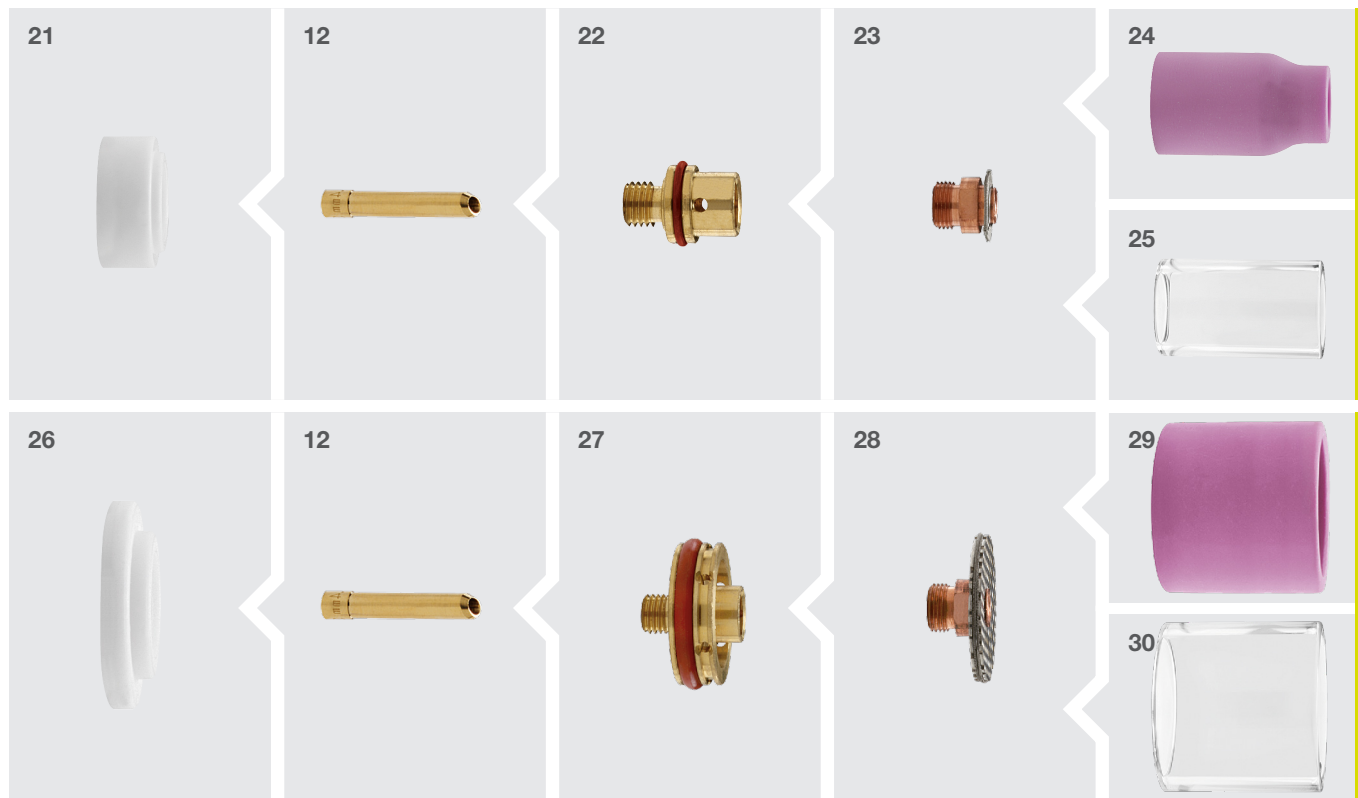

						
21 Insulator Gas Saver Heatshield	2HSGS-1	12 Collet Wedge	22 Collet Body Gas Saver	23 Tungsten Adapter with Screens	27 Collet Body Gas Saver LD	28 Tungsten Adapter with Screens
						
26 Insulator Gas Saver LD	2HSGSLD					
Size						
	Ø .020" (0.5 mm)	-	-	-	-	-
	Ø .040" (1.0 mm)	2C040GS	-	TAS040GS	-	TAS040GSLD
	Ø 1/16" (1.6 mm)	2C116GS	2CBGS-1	TAS116GS	-	TAS116GSLD
	Ø 3/32" (2.4 mm)	2C332GS	-	TAS332GS	2CBGSLD	TAS332GSLD
	Ø 1/8" (3.2 mm)	2C418GS	-	TAS418GS	-	TAS418GSLD

				
Size	30 Cup Pyrex LD (32,5 mm)	29 Cup LD (32,5 mm)	25 Cup Pyrex (32,5 mm)	24 Cup (32,50 mm)
#3	Ø 4.75 mm	-	-	-
#4	Ø 6.35 mm	-	-	2A4GS
#5	Ø 7.93 mm	-	-	2A5GS
#6	Ø 9.52 mm	-	-	2A6GS
#7	Ø 11.11 mm	-	-	2A7GS
#8	Ø 12.70 mm	-	-	2A8GS
#10	Ø 15.87 mm	-	D2P8GS	-
#18	Ø 28.50 mm	2P18GSLD	2A18GSLD	-

AIR COOLED SERIES

AE-17

TIGZONE®
TORCHES60
%DCWØ
0,5
-
4,0
mm150
A DC

115
A AC

TIGZONE AE-17 – aircooled TIG-Torch

The Torch

Designed for maximum comfort in a variety of applications.
Allround air-cooled torch

The Cable

Super-Flex® cables and Super-Soft® leather remains
flexible and ease to handle with a significant cable lifetime

The End-Connector

Available for all standard welding machines

DIN Norm

CE EN 60 974-7

The Handle

3 Different handle and switch options

TIGZONE AE-17 – Torch / Back End Consumables

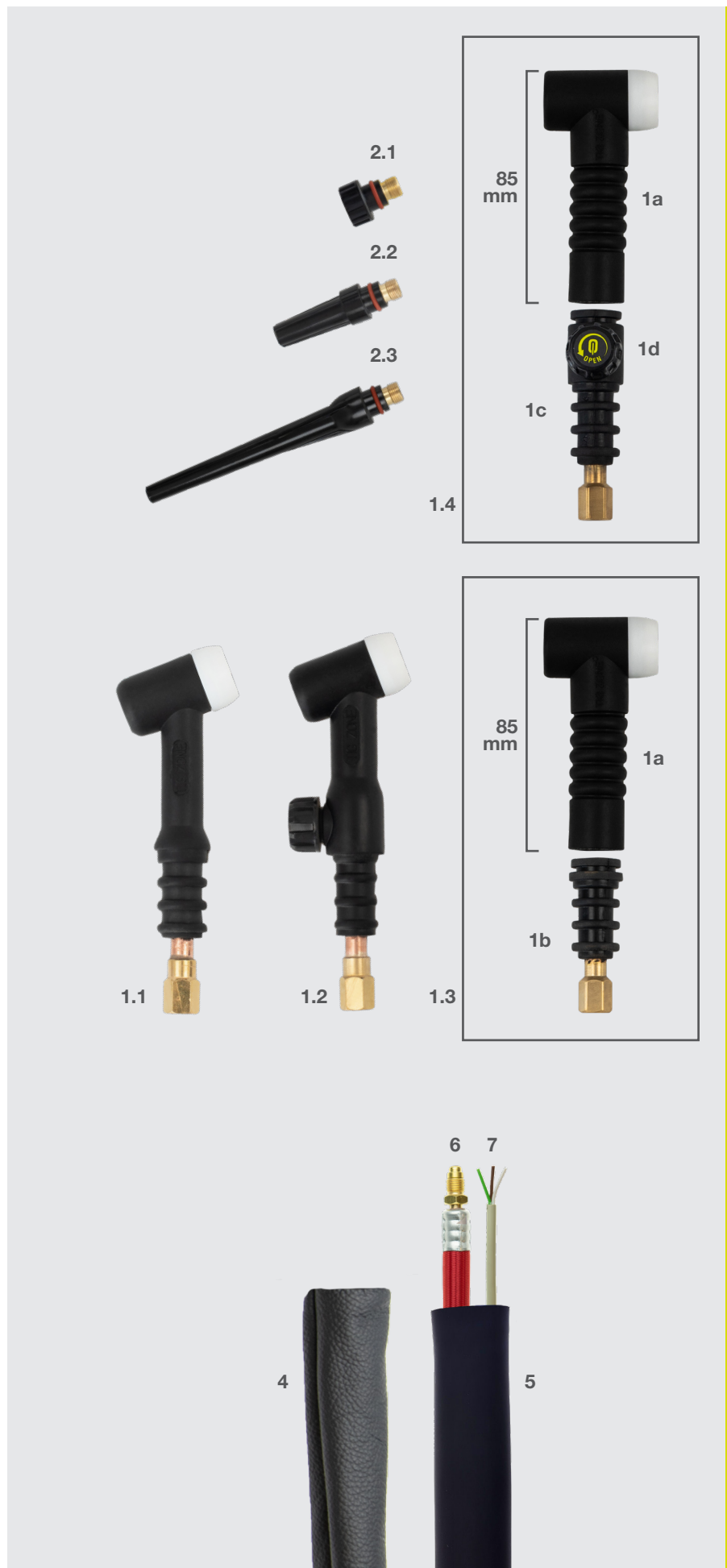

Torch Front Group

1	Torch Body incl. insulator (15)	
.1	AE-17	AE17
.2	AE-17V	AE17V
.3	AE-17F	85 mm AE17F
.4	AE-17FV	85 mm AE17FV
.a	17F	85 mm 17F
.b	AE-150TB	AE150TB
.c	AE-150VTB	AE150VTB
.d	VS-2	VS2

2	Backcap	
.1	short	57Y04
.2	medium	57Y02M
.3	long	57Y02

Cable Group

4	Cable cover leather	TZ-1022R-TIG
5	Cable cover 22x1.5mm	RS-22
6	Power Cable	
	4m	57Y01R-*
	4m SF	57Y01R-SF-*
	8m	57Y03R-*
	8m SF	57Y03R-SF-*
7	Control	MOQ 100m
	Standard (3x0.5mm)	LIYY-3x0,5
	U/D Torches (6x0.25mm)	LIYCY-6x0,25

* Please specify machine connections e.g. 1/4, 3/8 etc.

i H-100 Handle

Fits AE17/17F/17FV bodies.
Ordering Number: **H-100**



i Handles

More information regarding our **Handles** Group on page 2.

TIGZONE AE-17 – Front End Consumables Overview



TIGZONE AE-17 – Front End Consumables

Size	16 Collet Wedge	17 Collet	18 Collet Body	21 Gas Lens	24 Gas Lens	15 Insulator Standard	20 Insulator Gas Lens	23 Insulator LD Gas Lens
Ø .020" (0.5 mm)	-	-	10N21	45V29	45V0204	18CG		
Ø .040" (1.0 mm)	3C040GS	10N22	10N29	45V24			54N01	
Ø 1/16" (1.6 mm)	3C116GS	10N23	10N31	45V25	45V116			
Ø 3/32" (2.4 mm)	3C332GS	10N24	10N32	45V26	45V64			
Ø 1/8" (3.2 mm)	3C418GS	10N25	10N28	45V27	995795			
Ø 5/32" (4.0 mm)	3C532GS	54N20	406488	45V28	45V63			54N63

Size	19 Cup (46,83 mm)	19 Super Cup (Sil.Nitride)	19 Cup L (76 mm)	22 Cup (41,27 mm)	22 Super Cup (Sil.Nitride)	22 Cup L (76 mm)
#3 Ø 4.75 mm	-	-	-	-	-	-
#4 Ø 6.35 mm	10N50	10N50SC	10N50L	54N18	54N18SC	54N18L
#5 Ø 7.93 mm	10N49	10N49SC	10N49L	54N17	54N17SC	54N17L
#6 Ø 9.52 mm	10N48	10N48SC	10N48L	54N16	54N16SC	54N16L
#7 Ø 11.11 mm	10N47	10N47SC	10N47L	54N15	54N15SC	54N15L
#8 Ø 12.70 mm	10N46	10N46SC	-	54N14	54N14SC	54N14L
#10 Ø 15.87 mm	10N45	10N45SC	-	-	-	-
#11 Ø 17.50 mm	-	-	-	54N19L	-	-
#12 Ø 19.05 mm	10N44	10N44SC	-	-	-	-

Size	25 Cup (47,62 mm)	25 Super Cup (Sil.Nitride)	25 Cup L (70 mm)	25 Cup XL (84 mm)	25 Cup XXL (122 mm)
#3 Ø 4.75 mm	-	-	-	-	-
#4 Ø 6.35 mm	-	-	-	-	-
#5 Ø 7.93 mm	-	-	-	-	-
#6 Ø 9.52 mm	57N75	57N75SC	57N75L	57N75XL	57N75XXL
#7 Ø 11.11 mm	-	-	-	-	-
#8 Ø 12.70 mm	57N74	57N74SC	57N74L	57N74XL	57N74XXL
#10 Ø 15.87 mm	53N88	53N88SC	53N88L	53N88XL	53N88XXL
#12 Ø 19.05 mm	53N87	53N87SC	53N87L	53N87XL	53N87XXL

TIGZONE AE-17 – Front End Consumables

i Parts

These parts come in different **materials, variants** and **sizes**.

For additional information see below.

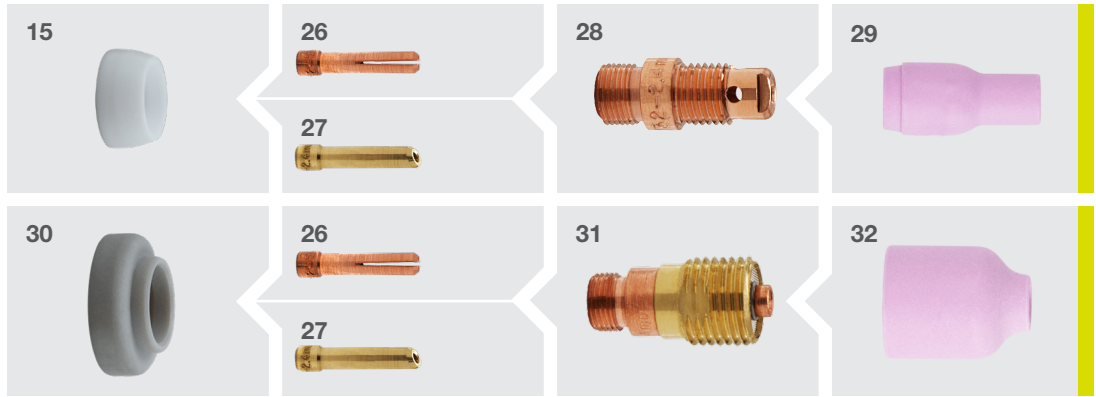

Size	15 Insulator Standard	30 Insulator Stubby Gas Lens	26 Stubby Collet	27 Collet Wedge	28 Short Collet Body	31 Stubby Gas Lens
Ø .020" (0.5 mm)			10N21S	-	4CB20	4GL20
Ø .040" (1.0 mm)			10N22S	4C040GS	4CB40	4GL40
Ø 1/16" (1.6 mm)	18CG	18CGG	10N23S	4C116GS	4CB116	4GL116
Ø 3/32" (2.4 mm)			10N24S	4C332GS	4CB332	4GL332
Ø 1/8" (3.2 mm)			10N25S	4C418GS	4CB418	4GL418
Ø 5/32" (4.0 mm)			4C532	4C532GS	4CB532	4GL532

Size	29 Cup (29,35 mm)	29 Super Cup (Sil.Nitride)	29 Cup L (48 mm)	29 Cup XL (63 mm)	32 Cup (25,40 mm)	32 Super Cup (Sil.Nitride)	32 Cup L (35 mm)	32 Cup XL (72 mm)
#3 Ø 4.75 mm	-	-	A796F70	A796F74	-	-	-	-
#4 Ø 6.35 mm	13N08	13N08SC	A796F71	A796F75	53N58	53N58SC	53N58L	53N58XL
#5 Ø 7.93 mm	13N09	13N09SC	A796F72	A796F76	53N59	53N59SC	53N59L	53N59XL
#6 Ø 9.52 mm	13N10	13N10SC	A796F73	A796F77	53N60	53N60SC	53N60L	53N60XL
#7 Ø 11.11 mm	13N11	13N11SC	-	-	53N61	53N61SC	53N61L	53N61XL
#8 Ø 12.70 mm	13N12	13N12SC	-	-	53N61S	53N61SSC	53N61SL	-
#10 Ø 15.87 mm	13N13	13N13SC	-	-	53N61S-10	-	-	-
#12 Ø 19.05 mm	-	-	-	-	-	-	-	-

TIGZONE AE-17 – Front End Consumables



Size	27 Insulator Gas Saver LD	27 Collet Wedge	43 Collet Body Gas Saver LD	44 Tungsten Adapter with Screens
Ø .020" (0.5 mm)	-	-	-	-
Ø .040" (1.0 mm)	-	4C040GS	-	TAS040GSLD
Ø 1/16" (1.6 mm)	-	4C116GS	-	TAS116GSLD
Ø 3/32" (2.4 mm)	4HSGSLD	4C332GS	4CBGSLD	TAS332GSLD
Ø 1/8" (3.2 mm)	-	4C418GS	-	TAS418GSLD
Ø 5/32" (4.0 mm)	-	4C532GS	-	TAS532GSLD

Size	45 Cup Pyrex LD (47,62 mm)	46 Cup LD GasSaver (47,62 mm)
#3	Ø 4.75 mm	-
#4	Ø 6.35 mm	-
#5	Ø 7.93 mm	-
#6	Ø 9.52 mm	-
#7	Ø 11.11 mm	-
#8	Ø 12.70 mm	-
#10	Ø 15.87 mm	-
#12	Ø 19.05 mm	-
#18	Ø 28.50 mm	2A12GSLD 4A18GSLD

Notes

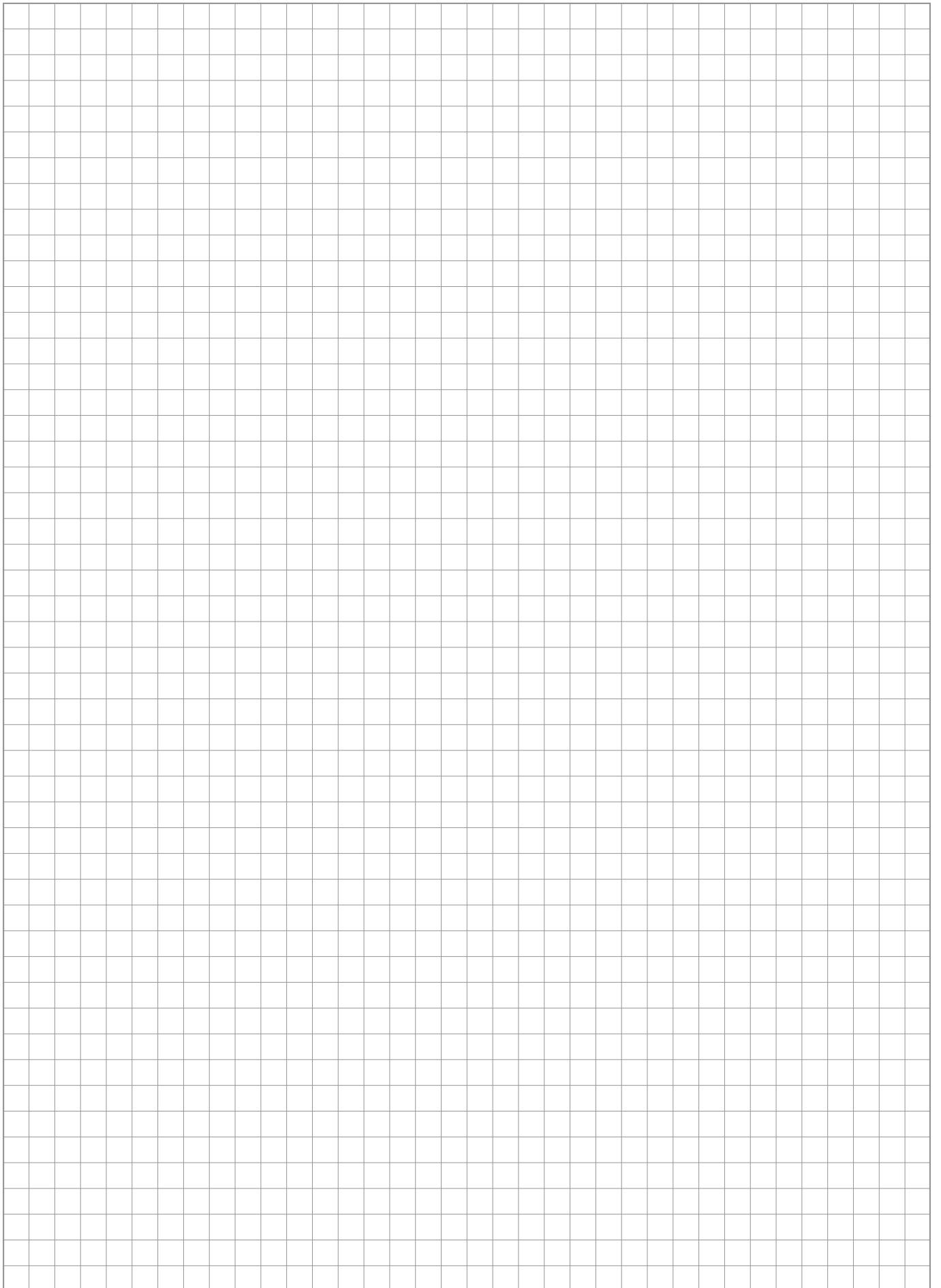

AIR COOLED SERIES

AE-26

TIGZONE®
TORCHES

TIGZONE AE-26 – aircooled TIG-Torch

The Torch

Top performing air-cooled torch for heavy-duty applications. Ideal torch for rugged fieldwork welding.

The End-Connector

Available for all standard welding machines

The Handle

Choose between the ERGO or HD handle series

The Cable

Super-Flex® cables and Super-Soft® leather remains flexible and ease to handle with a significant cable lifetime. A 2PC torch cable makes this an easy-to-repair and heavy-duty tig torch

DIN Norm

CE EN 60 974-7

TIGZONE AE-26 – Torch / Back End Consumables



Torch Front Group

1	Torch Body incl. insulator (15)	
.1	AE-26	AE26
.2	AE-26V	AE26V
.3	AE-26F	80 mm AE26F
.4	AE-26FV	80 mm AE26FV
.a	26F	80 mm 26F
.b	AE-200TB	AE200TB
.c	AE-200VTB	AE200VTB
.d	VS-1	VS1

2	Backcap	
.1	short	57Y04
.2	medium	57Y02M
.3	long	57Y02

Cable Group

4	Cable cover leather	TZ-1028R-TIG
5	Cable cover 25x1.5mm	RS-25
6	Power Cable	
	4m	46V28R-*
	4m SF	46V28R-SF-*
	8m	46V30R-*
	8m SF	46V30R-SF-*
7	Control	MOQ 100m
	Standard (3x0.5mm)	LIYY-3x0,5

* Please specify machine connections e.g. 1/4, 3/8 etc.

i H-200R Handle

Fits AE26/26F/26FV bodies.
Ordering Number: **H-200R**



i Handles

More information regarding our **Handles** Group on page 2.

TIGZONE AE-26 – Front End Consumables Overview



TIGZONE AE-26 – Front End Consumables

Size	16 Collet Wedge	17 Collet	18 Collet Body	21 Gas Lens	24 Gas Lens	15 Insulator Standard	20 Insulator Gas Lens	23 Insulator LD Gas Lens
Ø .020" (0.5 mm)	-	-	10N21	10N29	45V29	18CG	-	-
Ø .040" (1.0 mm)	3C040GS	10N22	10N30	45V24	45V0204	-	54N01	-
Ø 1/16" (1.6 mm)	3C116GS	10N23	10N31	45V25	45V116	-	-	-
Ø 3/32" (2.4 mm)	3C332GS	10N24	10N32	45V26	45V64	-	-	-
Ø 1/8" (3.2 mm)	3C418GS	10N25	10N28	45V27	995795	-	-	-
Ø 5/32" (4.0 mm)	3C532GS	54N20	406488	45V28	45V63	-	-	54N63

Size	19 Cup (46,83 mm)	19 Super Cup (Sil.Nitride)	19 Cup L (76 mm)	22 Cup (41,27 mm)	22 Super Cup (Sil.Nitride)	22 Cup L (76 mm)
#3 Ø 4.75 mm	-	-	-	-	-	-
#4 Ø 6.35 mm	10N50	10N50SC	10N50L	54N18	54N18SC	54N18L
#5 Ø 7.93 mm	10N49	10N49SC	10N49L	54N17	54N17SC	54N17L
#6 Ø 9.52 mm	10N48	10N48SC	10N48L	54N16	54N16SC	54N16L
#7 Ø 11.11 mm	10N47	10N47SC	10N47L	54N15	54N15SC	54N15L
#8 Ø 12.70 mm	10N46	10N46SC	-	54N14	54N14SC	54N14L
#10 Ø 15.87 mm	10N45	10N45SC	-	54N19L	-	-
#11 Ø 17.50 mm	-	-	-	54N19L	-	-
#12 Ø 19.05 mm	10N44	10N44SC	-	-	-	-

Size	25 Cup (47,62 mm)	25 Super Cup (Sil.Nitride)	25 Cup L (70 mm)	25 Cup XL (84 mm)	25 Cup XXL (122 mm)
#3 Ø 4.75 mm	-	-	-	-	-
#4 Ø 6.35 mm	-	-	-	-	-
#5 Ø 7.93 mm	-	-	-	-	-
#6 Ø 9.52 mm	57N75	57N75SC	57N75L	57N75XL	57N75XXL
#7 Ø 11.11 mm	-	-	-	-	-
#8 Ø 12.70 mm	57N74	57N74SC	57N74L	57N74XL	57N74XXL
#10 Ø 15.87 mm	53N88	53N88SC	53N88L	53N88XL	53N88XXL
#12 Ø 19.05 mm	53N87	53N87SC	53N87L	53N87XL	53N87XXL

TIGZONE AE-26 – Front End Consumables

i Parts

These parts come in different **materials, variants** and **sizes**.

For additional information see below.

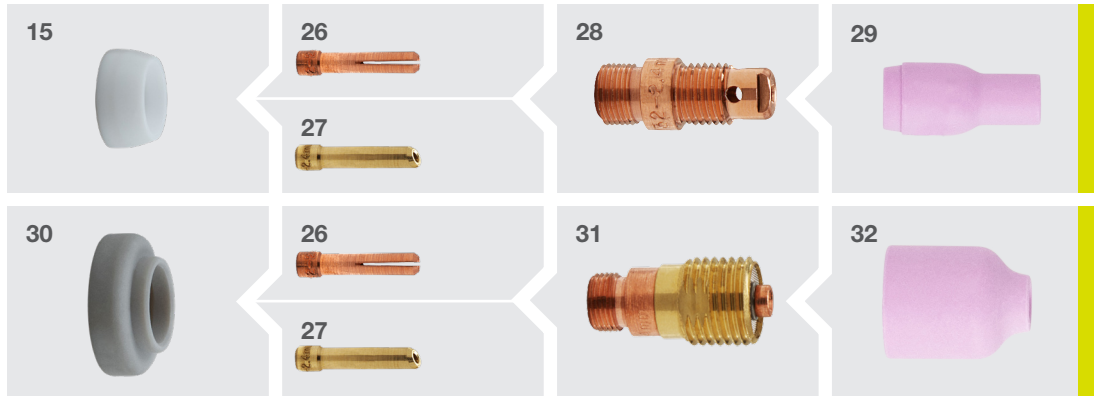

Size	15 Insulator Standard	30 Insulator Stubby Gas Lens	26 Stubby Collet	27 Collet Wedge	28 Short Collet Body	31 Stubby Gas Lens
Ø .020" (0.5 mm)			10N21S	-	4CB20	4GL20
Ø .040" (1.0 mm)			10N22S	4C040GS	4CB40	4GL40
Ø 1/16" (1.6 mm)	18CG	18CGG	10N23S	4C116GS	4CB116	4GL116
Ø 3/32" (2.4 mm)			10N24S	4C332GS	4CB332	4GL332
Ø 1/8" (3.2 mm)			10N25S	4C418GS	4CB418	4GL418
Ø 5/32" (4.0 mm)			4C532	4C532GS	4CB532	4GL532

Size	29 Cup (29,35 mm)	29 Super Cup (Sil.Nitride)	29 Cup L (48 mm)	29 Cup XL (63 mm)	32 Cup (25,40 mm)	32 Super Cup (Sil.Nitride)	32 Cup L (35 mm)	32 Cup XL (72 mm)
#3 Ø 4.75 mm	-	-	A796F70	A796F74	-	-	-	-
#4 Ø 6.35 mm	13N08	13N08SC	A796F71	A796F75	53N58	53N58SC	53N58L	53N58XL
#5 Ø 7.93 mm	13N09	13N09SC	A796F72	A796F76	53N59	53N59SC	53N59L	53N59XL
#6 Ø 9.52 mm	13N10	13N10SC	A796F73	A796F77	53N60	53N60SC	53N60L	53N60XL
#7 Ø 11.11 mm	13N11	13N11SC	-	-	53N61	53N61SC	53N61L	53N61XL
#8 Ø 12.70 mm	13N12	13N12SC	-	-	53N61S	53N61SSC	53N61SL	-
#10 Ø 15.87 mm	13N13	13N13SC	-	-	53N61S-10	-	-	-
#12 Ø 19.05 mm	-	-	-	-	-	-	-	-

TIGZONE AE-26 – Front End Consumables

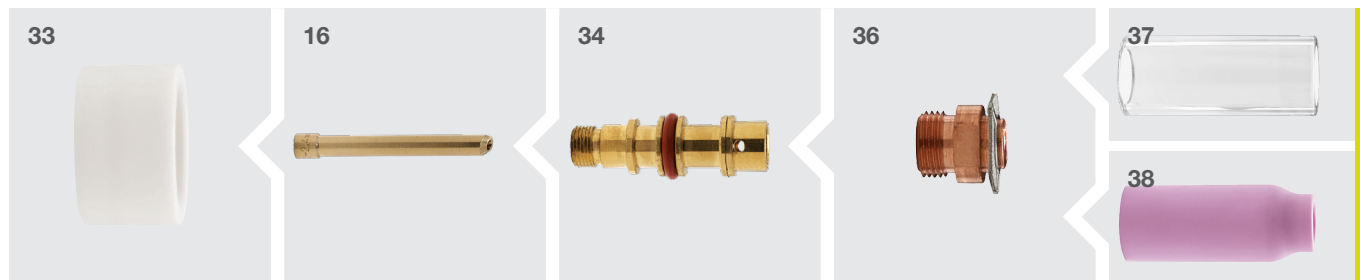

Size							
Ø .020" (0.5 mm)		-	-	-	#3	Ø 4.75 mm	-
Ø .040" (1.0 mm)		3C040GS		TAS040GS	#4	Ø 6.35 mm	3A4GS
Ø 1/16" (1.6 mm)		3C116GS		TAS116GS	#5	Ø 7.93 mm	3A5GS
Ø 3/32" (2.4 mm)	3HSGS	3C332GS	3CBGS	TAS332GS	#6	Ø 9.52 mm	3A6GS
Ø 1/8" (3.2 mm)		3C418GS		TAS418GS	#7	Ø 11.11 mm	3A7GS
Ø 5/32" (4.0 mm)		3C532GS		TAS532GS	#8	Ø 12.70 mm	3A8GS
					#10	Ø 15.87 mm	D3P8GS
					#12	Ø 19.05 mm	-

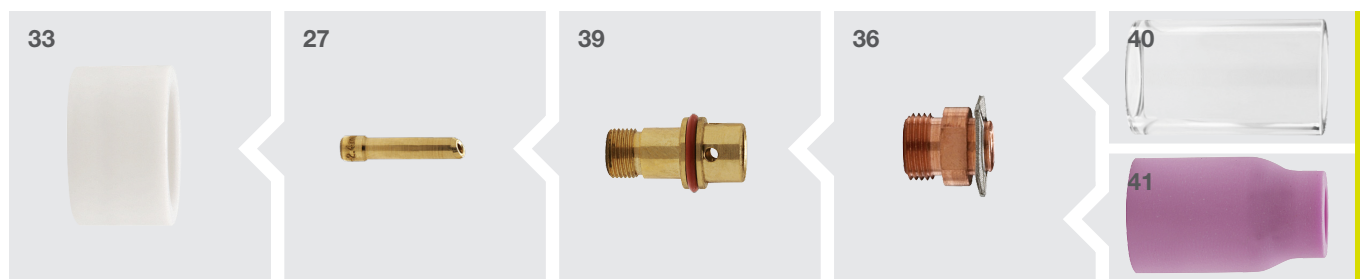

Size							
Ø .020" (0.5 mm)		-	-	-	#3	Ø 4.75 mm	-
Ø .040" (1.0 mm)		4C040GS		TAS040GS	#4	Ø 6.35 mm	2A4GS
Ø 1/16" (1.6 mm)		4C116GS		TAS116GS	#5	Ø 7.93 mm	2A5GS
Ø 3/32" (2.4 mm)	3HSGS	4C332GS	4CBGS	TAS332GS	#6	Ø 9.52 mm	2A6GS
Ø 1/8" (3.2 mm)		4C418GS		TAS418GS	#7	Ø 11.11 mm	2A7GS
Ø 5/32" (4.0 mm)		4C532GS		TAS532GS	#8	Ø 12.70 mm	2A8GS
					#10	Ø 15.87 mm	D2P8GS
					#12	Ø 19.05 mm	-

TIGZONE AE-26 – Front End Consumables



Size	27 Insulator Gas Saver LD	27 Collet Wedge	43 Collet Body Gas Saver LD	44 Tungsten Adapter with Screens
Ø .020" (0.5 mm)	-	-	-	-
Ø .040" (1.0 mm)	-	-	-	-
Ø 1/16" (1.6 mm)	-	4C040GS	-	TAS040GSLD
Ø 3/32" (2.4 mm)	4HSGSLD	4C116GS	4CBGSLD	TAS116GSLD
Ø 1/8" (3.2 mm)	-	4C332GS	-	TAS332GSLD
Ø 5/32" (4.0 mm)	-	4C418GS	-	TAS418GSLD
	-	4C532GS	-	TAS532GSLD

Size	45 Cup Pyrex LD (47,62 mm)	46 Cup LD GasSaver (47,62 mm)
#3	Ø 4.75 mm	-
#4	Ø 6.35 mm	-
#5	Ø 7.93 mm	-
#6	Ø 9.52 mm	-
#7	Ø 11.11 mm	-
#8	Ø 12.70 mm	-
#10	Ø 15.87 mm	-
#12	Ø 19.05 mm	-
#18	Ø 28.50 mm	2A12GSLD
	4P18GSLD	4A18GSLD

AIR COOLED SERIES
AE-24

TIGZONE®
TORCHES



TIGZONE AE-24 – aircooled TIG-Torch

The Torch

Innovative torch profile, especially in limited-access areas.
75mm and 120mm flex-neck option.

The End-Connector

Available for all standard welding machines

The Handle

3 Different handle and switch options

The Cable

Super-Flex® cables and Super-Soft® leather remains flexible and ease to handle with a significant cable lifetime

DIN Norm

CE EN 60 974-7

TIGZONE AE-24 – Torch / Back End Consumables

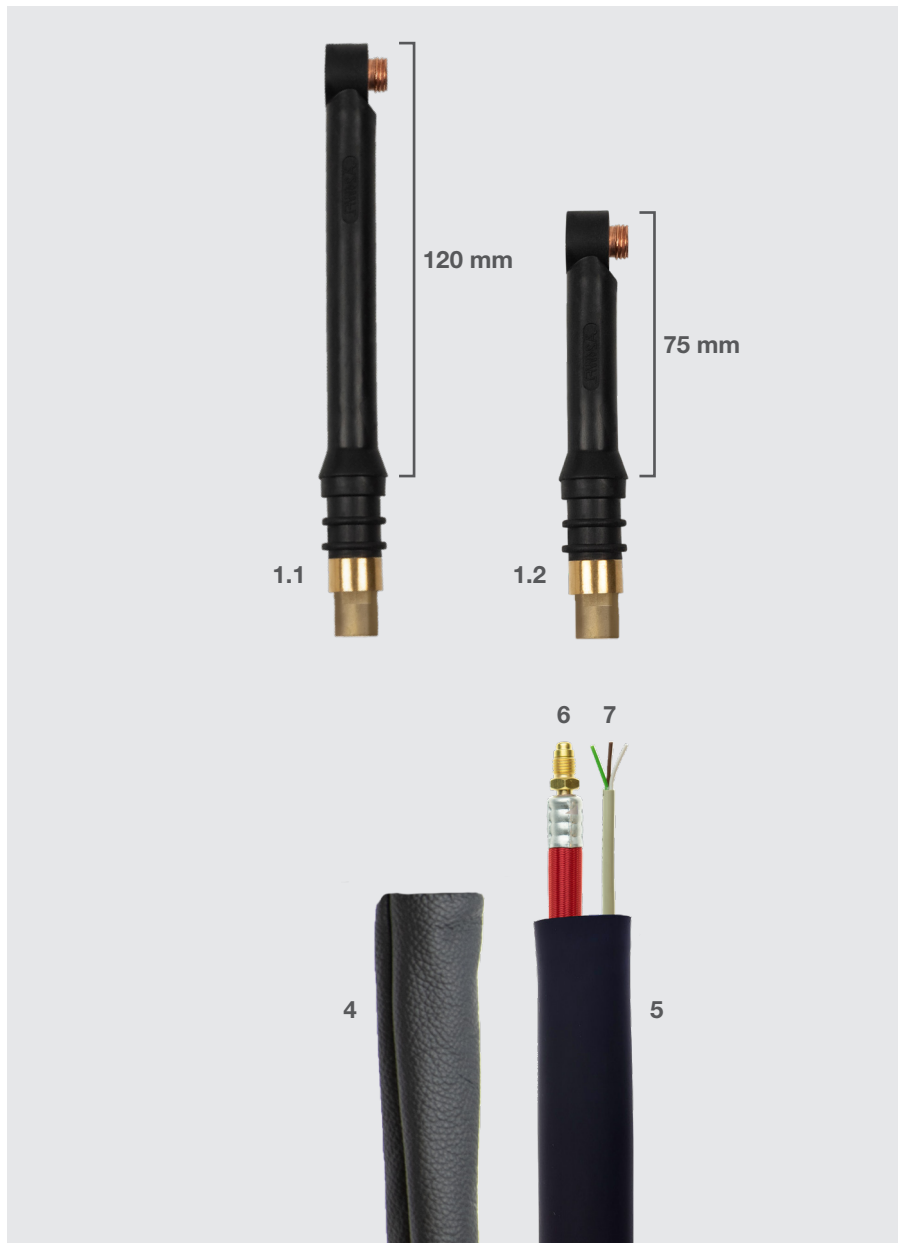

Torch Front Group

1	Torch Body incl. insulator (10)	
.1	AE-24GF 120mm	AE24GF
.2	AE-24GFS 75mm	AE24GFS

Cable Group

4	Cable cover leather	TZ-1022R-TIG
5	Cable cover 22x1.5mm	RS-22
6	Power Cable	
	4m	57Y01R-*
	4m SF	57Y01R-SF-*
	8m	57Y03R-*
	8m SF	57Y03R-SF-*
7	Control	MOQ 100m
	Standard (3x0.5mm)	LIYY-3x0,5
	U/D Torches (6x0.25mm)	LIYCY-6x0,25

* Please specify machine connections e.g. **1/4, 3/8** etc.

i Handles

More information regarding our **Handles** Group on page 2.

Size	10 Insulator	11 Collet	12 Gas Lens	13 Cup #6 Ø 9.52 mm
Ø .020" (0.5 mm)	-	-	-	-
Ø .040" (1.0 mm)	-	-	-	-
Ø 1/16" (1.6 mm)	598882M	13N21JA	45V42MS	53N60ES
Ø 3/32" (2.4 mm)		13N22JA	45V43MS	
Ø 1/8" (3.2 mm)		13N23JA	45V44MS	
		13N24JA	45V45MS	

Notes

